

Finite Element Analysis of Voice coil Actuator using monolithic mechanism

Mr. Ganesh Gulabrao Saner
Under the Guidance of
Prof. A. B. Gaikwad.
ME Mechanical(Design Engg.)
Prof. S.B.Jadhav
ME Mechanical(Design Engg.)
Department of Mechanical Engineering,
Dr. D. Y. Patil SOE Lohegaon, Pune – 412105.

Abstract :

Voice coil actuator are direct drive limited motion devices that utilize permanent magnet field and coil winding to produce a force that is proportional to the current applied to the coil. These non-mobile electromagnetic coupling devices are used in linear and rotary motion applications that require linear force or torque output and high acceleration or high frequency actuation. Generally used in loud speakers, VCA (Voice Coil Actuator) are gaining popularity in applications where tight servo control is necessary. The electromechanical conversion of VCA is based on Lorentz force principle. VCA need to be analysed to determine Power Spectral Density (PSD) plots, which are determined by Finite element analysis of VCA. Modal analysis and Random Vibration Analysis is performed to determine desired parameters.

Keywords: Vibration energy harvesting, Power spectral density, FEA, Voice Coil Actuator

1. INTRODUCTION

The electromechanical conversion of voice coil actuator is governed by Lorentz force law. This Lorentz law states that if a current carrying conductor is placed in magnetic field, a force 'F' will act upon it, Magnitude of this force determined by the flux density B, current flowing through conductor 'I' and orientation of magnetic field and current vectors. Additionally if a total of 'N' conductors (in series) are placed in magnetic field. The magnitude of force acting on these conductors follows below equation;

$$F=KBLIN \quad \dots(1.1)$$

In Voice coil, length of conductor and magnetic field are constant, thus generated force is directly proportional to the input current. Again conductor moving through a magnetic field will have voltage induced across conductors.

Boundary conditions:

Geometry	Construction volume V_{cons}	1 cm ³
	Clearance gap(coil/ magnet)	0.5 mm

Dr. D. Y. Patil School of Engineering, Lohegaon, M.E. (Mechanical) (Design Engineering)

	Z_{\max} maximum inner displacement	1mm
Magnet	Residual flux density B_r	1.1 T
	Ω_{mag} Density of magnet	7.6 g/cm ³
Coil	Copper fill factor K_{co}	0.6
	Wire diameter d_{co}	40 μm
	Resistance per unit R'	13.6 Ω/m
Back Iron	Density of back iron material	7.85 g/cm ³
Other	Excitation amplitude	10 m/s ²
	Excitation Frequency	100 Hz
	Parasitic damping	0.1 N/m/s

The magnitude of voltage, E , is dependent on the magnetic flux density, B , the length of the conductor L , and speed of the conductor v , as conductor traverses the field. The voltage potential induced in the conductor is given as;

$$E = kBLvN \quad \dots (1.2)$$

Combining equation (1.1) and (1.2), it can be said that In a device that contains a permanent magnetic field and coil winding moving in the field will produce a force directly proportional to current flowing through the coil and voltage proportional to velocity of the coil.

Voice coil actuator can be simply represented as a tubular coil of wire situated in radially oriented magnetic field as shown in figure;

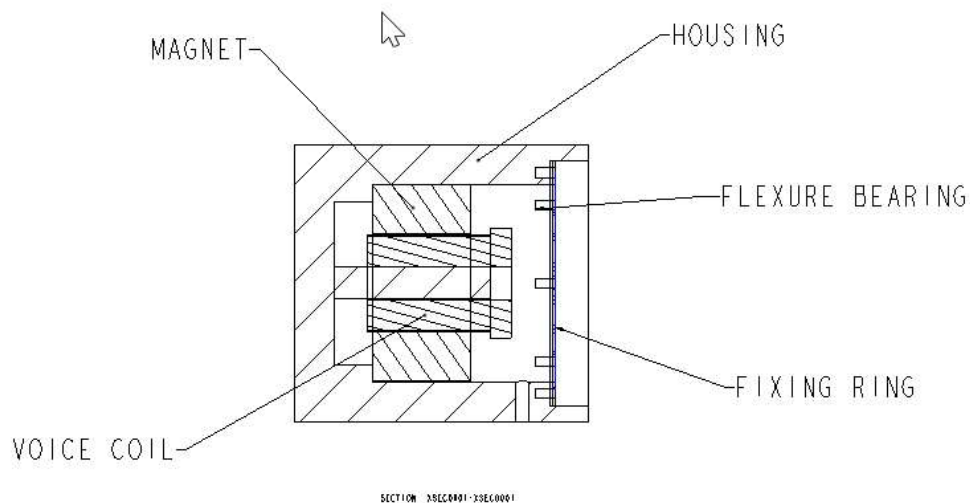

Fig. Voice Coil Actuator Assembly

Problem Statement

To cater the need of energy requirements of equipment, sensors (WSN), currently used batteries having limited life which requires frequent replacement. It involves considerable time, manpower and management. Also, in WSN's environmental energy in the form such as heat, light, fluid flow, kinetic energy or vibrations is dissipated and wasted without its use. This is sort of energy loss.

To cater the need of energy requirements of sensors (WSN), make efficient use of energy harvesting applications, replace limited life batteries with electromagnetic conversion mechanism which converts

environmental energy forms such as vibration energy into electrical energy to drive these sensors and reducing wastage in form of vibrations.

Objectives

To solve the above-mentioned problem, the main aim/objective of the project is summarized below;

1. To cater the need of energy requirements of sensors (WSN), make efficient use of energy harvesting applications.
2. To replace limited life batteries with electromagnetic conversion mechanism which converts environmental energy forms such as vibration energy into electrical energy to drive these sensors.
3. To reduce wastage of environmental energy in form of vibrations.
4. To validate the Analytical, FEA and Experimental results.

Scope

1. The focus of this study is to design a electromagnetic vibration transducer.
2. The scope of this study is mainly focused on design and development of analytical model of electromagnetic vibration transducer.
3. The scope of this study is mainly focused on design and development of Mathematical model of electromagnetic vibration transducer. This model is validated using ANSYS model.
4. The scope of this study is mainly focussed on design and development of practical model of electromagnetic vibration transducer. Develop a general optimization approach for the dimensioning of the electromagnetic coupling architecture components.

So, this project develops the integration of the optimization approach in the design flow of an application-oriented prototype development of a resonant electromagnetic vibration transducer and compare it analytically and experimentally.

Methodology

1. Dimensioning of the electromagnetic coupling architecture components.
2. CAD model generation (Creo 4.0)
3. Finite Element Analysis (ANSYS)
4. Analytical Representation

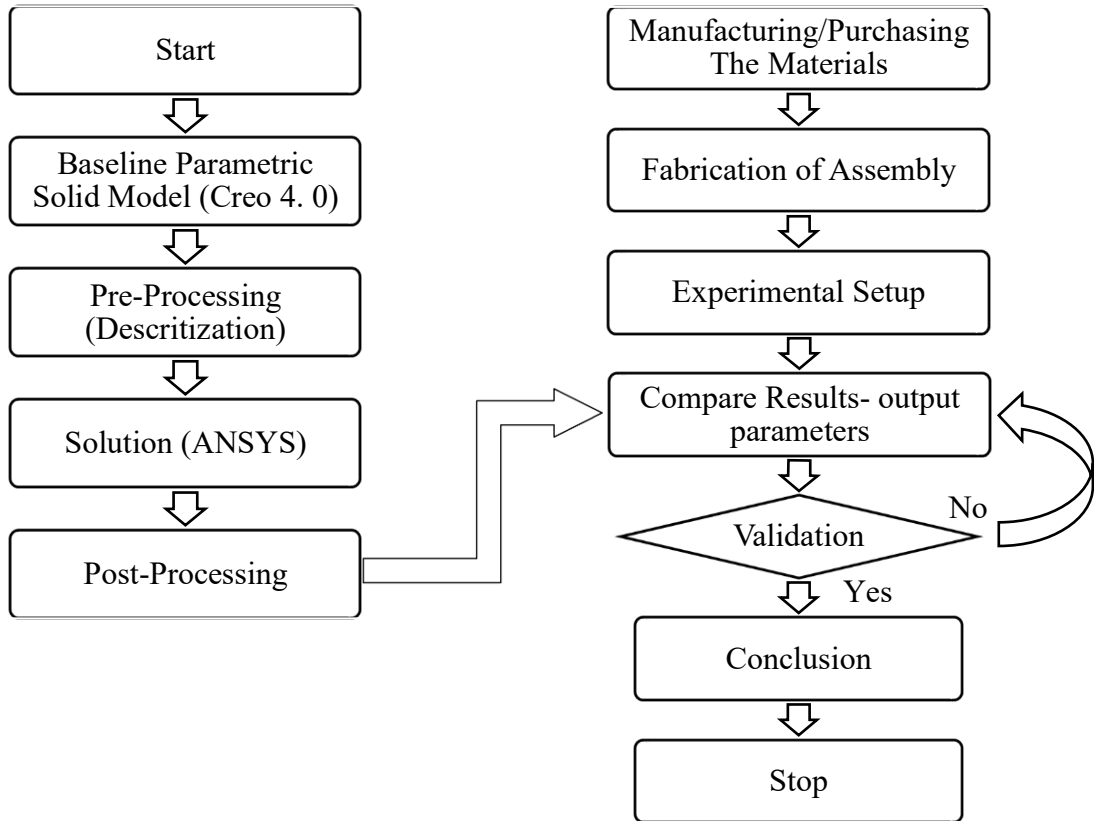

Figure 1.1 Process Methodology Flowchart

II. LITERATURE REVIEW

1. Vibration energy harvesting by magnetostrictive material

A new class of vibration energy harvester based on magnetostrictive material (MsM), Metglas 2605SC, is designed, developed and tested. It contains two submodules: an MsM harvesting device and an energy harvesting circuit. Compared to piezoelectric materials, the Metglas 2605SC offers advantages including higher energy conversion efficiency, longer life cycles, lack of depolarization and higher flexibility to survive in strong ambient vibrations. To enhance the energy conversion efficiency and alleviate the need of a bias magnetic field, Metglas ribbons are transversely annealed by a strong magnetic field along their width direction. To analyze the MsM harvesting device a generalized electromechanical circuit model is derived from Hamilton's principle in conjunction with the normal mode superposition method based on Euler-Bernoulli beam theory. The MsM harvesting device is equivalent to an electromechanical gyrator in series with an inductor. In addition, the proposed model can be readily extended to a more practical case of a cantilever beam element with a tip mass. The energy harvesting circuit, which interfaces with a wireless sensor and accumulates the harvested energy into an ultracapacitor, is designed on a printed circuit board (PCB) with plane dimension 25 mm × 35 mm. It mainly consists of a voltage quadrupler, a 3 F ultracapacitor and a smart regulator. The output DC voltage from the PCB can be adjusted within 2.0–5.5 V. In experiments, the maximum output power and power density on the resistor can reach 200 μW and 900 $\mu\text{W cm}^{-3}$, respectively, at a low frequency of 58 Hz. For a working prototype under a vibration with resonance frequency of 1.1 kHz and peak acceleration of 8.06 m s^{-2} (0.82 g), the average power and power density during charging the ultracapacitor can achieve 576 μW and 606 $\mu\text{W cm}^{-3}$, respectively, which compete favorably with piezoelectric vibration energy harvesters.

2. On energy harvesting from ambient vibration

Future MEMS devices will harvest energy from their environment. One can envisage an autonomous condition monitoring vibration sensor being powered by that same vibration, and transmitting data over a wireless link; inaccessible or hostile environments are obvious areas of application. The base excitation of an elastically mounted magnetic seismic mass moving past a coil, considered previously by several authors, is analysed in detail. The amplitude of the seismic mass is limited in any practical device and this, together with the magnitude and frequency of the excitation define the maximum power that can be extracted from the environment. The overall damping coefficient (part of which is mechanical) is associated with the harvesting and dissipation of energy and also the transfer of energy from the vibrating base into the system. It is shown that net energy flow from the base through the damper is positive (negative) for $\omega < \omega_0$, but is zero when $\omega = \omega_0$. The mechanical part of the damper cannot contribute more power than it dissipates and is neutral, at best, when $\omega = \omega_0$ [1]. Maximum power is delivered to an electrical load when its resistance is equal to the sum of the coil internal resistance and the electrical analogue of the mechanical damping coefficient, which differs from what has been claimed. A highly damped system has the advantage of harvesting energy over a wider band of excitation frequencies on either side of the natural frequency, is smaller, but will harvest marginally less power. One possible strategy for variable amplitude excitation is proposed.

3. Energy Scavenging for Wireless Sensor Nodes with a Focus on Vibration to Electricity Conversion

The vast reduction in size and power consumption of CMOS circuitry has led to a large research effort based around the vision of ubiquitous networks of wireless communication nodes. As the networks, which are usually designed to run on batteries, increase in number and the devices decrease in size, the replacement of depleted batteries is not practical. Methods of scavenging ambient power for use by low power wireless electronic devices have been explored in an effort to make the wireless nodes and resulting

wireless sensor networks indefinitely self-contained. After a broad survey of potential energy scavenging methods, the conversion of ambient vibrations to electricity was chosen as a method for further research. Converters based on both piezoelectric and electrostatic (capacitive) coupling were pursued. Both types of converters were carefully modeled. Designs were optimized based on the models developed within in total size constraint of 1 cm³. Test results from the piezoelectric converters demonstrate power densities of about 200 $\mu\text{W}/\text{cm}^3$ from input vibrations of 2.25 m/s² at 120 Hz. Furthermore, test results matched simulated outputs very closely thus verifying the validity of the model as a basis for design.

One of the piezoelectric converters was used to completely power a small wireless sensor device from vibrations similar to those found in common environments. Electrostatic converters were designed for a category of MEMS processes in which a structural MEMS device is patterned in the top layer of a Silicon on Insulator (SOI) wafer. Simulation results show a maximum power density of 110 $\mu\text{W}/\text{cm}^3$ from the same vibration source. Initial electrostatic converter prototypes were fabricated in a SOI MEMS process. Prototypes have been tested and when manually actuated have demonstrated a net electrical power increase due to mechanical work done on the converter. However, a fully functional power generator driven by vibrations has yet to be demonstrated.

4. A micro electromagnetic generator for vibration energy harvesting

Vibration energy harvesting is receiving a considerable amount of interest as a means for powering wireless sensor nodes. This paper presents a small (component volume 0.1 cm³, practical volume 0.15 cm³) electromagnetic generator utilizing discrete components and optimized for a low ambient vibration level based upon real application data. The generator uses four magnets arranged on an etched cantilever with a wound coil located within the moving magnetic field. Magnet size and coil properties were optimized, with the final device producing 46 μW in a resistive load of 4 k Ω from just 0.59 m s⁻² acceleration levels at its resonant frequency of 52 Hz. A voltage of 428 mV_{rms} was obtained from the generator with a 2300 turn coil which has proved sufficient for subsequent rectification and voltage step-up circuitry. The generator delivers 30% of the power supplied from the environment to useful electrical power in the load. This generator compares very favourably with other demonstrated examples in the literature, both in terms of normalized power density and efficiency.

5. Electrostatic Vibration-to-Electric Energy Conversion

Ultra-Low-Power electronics can perform useful functions with power levels as low as 170 nW. This makes them amenable to powering from ambient sources such as vibration. In this case, they can become autonomous. Motivated by this application, this thesis provides the necessary tools to analyze, design and fabricate MEMS devices capable of electrostatic vibration-to-electric energy conversion at the microwatt level. The fundamental means of energy conversion is a variable capacitor that is excited through a generating energy conversion cycle with every vibration cycle of the converter. This thesis presents a road map on how to design MEMS electrostatic vibration-to electric energy converters. A proposed converter is designed to illustrate the design process, and is based on vibration levels typical of rotating machinery, which are around 2% of the acceleration of gravity from 1-5 kHz. The converter consists of a square centimeter with a 195 mg proof mass which travels $\pm 200 \mu\text{m}$. This mass and travel can couple to a sinusoidal acceleration source of 0.02g at 2.5 kHz, typical of rotating machinery, so as to capture 24 nJ per cycle. This moving proof mass is designed to provide a variable capacitor ranging from 1 pF to 80 pF. Adding a capacitor of 88 pF in parallel with this device will result in a capacitance change from 168 pF to 89 pF that is required to extract 24 nJ using a charge-constrained cycle. This device can be attached to power electronics that implement a charge-constrained cycle and deliver 0.5 nJ back to the reservoir for a total power output of 1.3 μW at 2.5 kHz. The efficiency of the electrical conversion is 2%. Including packaging, the power per volume would be 0.87 $\mu\text{W}/\text{cm}^3$ and the power per mass would be 1.3 $\mu\text{W}/\text{g}$. System improvements are also identified such as those that address the principal sources of loss. For example, decreasing the output capacitance of the MOSFET switches from 10 pF to 1 pF, while keeping the energy conversion cycle the same, results in an energy output of 13 nJ out of 24 nJ, for an efficiency of 54% and a power output of 33 μW . This argues strongly for the use of integrated circuits in which the output capacitance of the MOSFET switches can be reduced for this application.

6. Design and experimental characterization of a tuneable vibration-based electromagnetic micro-generator

Vibration-based micro-generators, as an alternative source of energy, have become increasingly significant in the last decade. This paper presents a new tunable electromagnetic vibration-based micro-generator. Frequency tuning is realized by applying an axial tensile force to the micro-generator. The dimensions of the generator, especially the dimensions of the coil and the air gap between magnets, have been optimized to maximize the output voltage and power of the micro-generator. The resonant frequency has been successfully tuned from 67.6 to 98 Hz when various axial tensile forces were applied to the structure. The generator produced a power of 61.6–156.6 W over the tuning range when excited at vibrations of 0.59 m s^{-2} . The tuning mechanism has little effect on the total damping. When the tuning force applied on the generator becomes larger than the generator's inertial force, the total damping increases resulting in reduced output power. The resonant frequency increases less than indicated from simulation and approaches that of a straight tensioned cable when the force associated with the tension in the beam becomes much greater than the beam stiffness. The test results agree with the theoretical analysis presented.

IIa. Closure of The Literature Review

From the previous studies and the literature review, it can be noted that the following research areas need to be addressed for improving Vibration damping and energy harvesting characteristics.

- Piezoelectric vibration energy harvester has highest energy harvesting characteristics but they are having high costs and not suitable for heavy applications.
- Electromagnetic vibration energy harvester has comparatively lesser energy harvesting characteristics but these are cheaper and suitable for heavy applications. Therefore, for practical purposes, the electromagnetic energy harvester are strongly recommended [4].
- It is suggested to further study on the design optimization of the Voice coil actuator using electromagnetic principle for more efficient and reliable vibration energy harvesting components [4].
- The applied coupling architectures have yet not been compared and the question of which of them performs best remain unanswered.

III. FEA OF VOICE COIL ACTUATOR

The Finite Element Method (FEM), is a numerical method for solving problems of engineering and mathematical physics. Typical problem areas of interest include structural analysis, heat transfer, fluid flow, mass transport, and electromagnetic potential. The analytical solution of these problems generally require the solution to boundary value problems for partial differential equations. The finite element method formulation of the problem results in a system of algebraic equations. The method yields approximate values of the unknowns at the discrete number of points over the domain. To solve the problem, it subdivides a large problem into smaller, simpler parts that are called finite elements. The simple equations that model these finite elements are then assembled into a larger system of equations that models the entire problem. FEM then uses variational methods from the calculus of variations to approximate a solution by minimizing an associated error function.

Studying or analyzing a phenomenon with FEM is often referred to as Finite Element Analysis (FEA).

3.1 Basic Concept of FEM

Dr. D. Y. Patil School of Engineering, Lohegaon, M.E. (Mechanical) (Design Engineering)

The subdivision of a whole domain into simpler parts has several advantages:

- Accurate representation of complex geometry
- Inclusion of dissimilar material properties
- Easy representation of the total solution
- Capture of local effects

A typical work out of the method involves, dividing the domain of the problem into a collection of subdomains, with each subdomain represented by a set of element equations to the original problem, followed by systematically recombining all sets of element equations into a global system of equations for the final calculation. The global system of equations has known solution techniques and can be calculated from the initial values of the original problem to obtain a numerical answer.

In the first step above, the element equations are simple equations that locally approximate the original complex equations to be studied, where the original equations are often Partial Differential Equations (PDE). To explain the approximation in this process, FEM is commonly introduced as a special case of the Galerkin method. The process, in mathematical language, is to construct an integral of the inner product of the residual and the weight functions and set the integral to zero. In simple terms, it is a procedure that minimizes the error of approximation by fitting trial functions into the PDE. The residual is the error caused by the trial functions, and the weight functions are polynomial approximation functions that project the residual. The process eliminates all the spatial derivatives from the PDE, thus approximating the PDE locally with;

- A set of algebraic equations for steady-state problems
- A set of ordinary differential equations for transient problems

These equation sets are the element equations. They are linear if the underlying PDE is linear, and vice versa. Algebraic equation sets that arise in the steady-state problems are solved using numerical linear algebra methods, while ordinary differential equation sets that arise in the transient problems are solved by numerical integration using standard techniques such as Euler's method or the Runge-Kutta method.

In the next step above, a global system of equations is generated from the element equations through a transformation of coordinates from the subdomains local nodes to the domain's global nodes. This spatial transformation includes appropriate orientation adjustments as applied to the reference coordinate system. The process is often carried out by FEM software using coordinate data generated from the subdomains.

FEM is best understood from its practical application, known as Finite Element Analysis (FEA). FEA is a computational tool for performing engineering analysis. It includes the use of mesh generation techniques for dividing a complex problem into small elements, as well as the use of software program coded with the FEM algorithm. In applying FEA, the complex problem is usually a physical system with the underlying physics such as the Euler-Bernoulli beam equation, the heat equation, or the Navier-Stokes equations expressed in either PDE or integral equations, while the divided small elements of the complex problem represent different areas in the physical system.

FEA is a good choice for analyzing problems over complicated domains (like cars and oil pipelines), when the domain changes (as during a solid-state reaction with a moving boundary), when the desired precision varies over the entire domain, or when the solution lacks smoothness. FEA simulations provide a valuable resource as they remove multiple instances of creation and testing of hard prototypes for various high-fidelity situations. For instance, in a frontal crash simulation it is possible to increase prediction accuracy in "important" areas like the front of the car and reduce it in its rear (thus reducing cost of the simulation). Another example would be in numerical weather prediction, where it is more important to have accurate predictions over developing highly nonlinear phenomena (such as tropical cyclones in the atmosphere, or eddies in the ocean) rather than relatively calm areas.

3.2 Assumptions Made in FEA

Following assumptions were made while performing finite Element Analysis;

- Material properties are uniform and accurate.
- The part created in CAD software is assumed to accurate and similar to that of the manufactured part.
- The loading and boundary conditions are assumed to capture the real experimental scenario.
- The speed of the top plate is chosen 15.6 m/s in the compression test.
- A coefficient of friction between the top platen and model and between cells wall was used 0.3.

3.2 Pre-Processing

3.2.1 Discretization (Meshing)

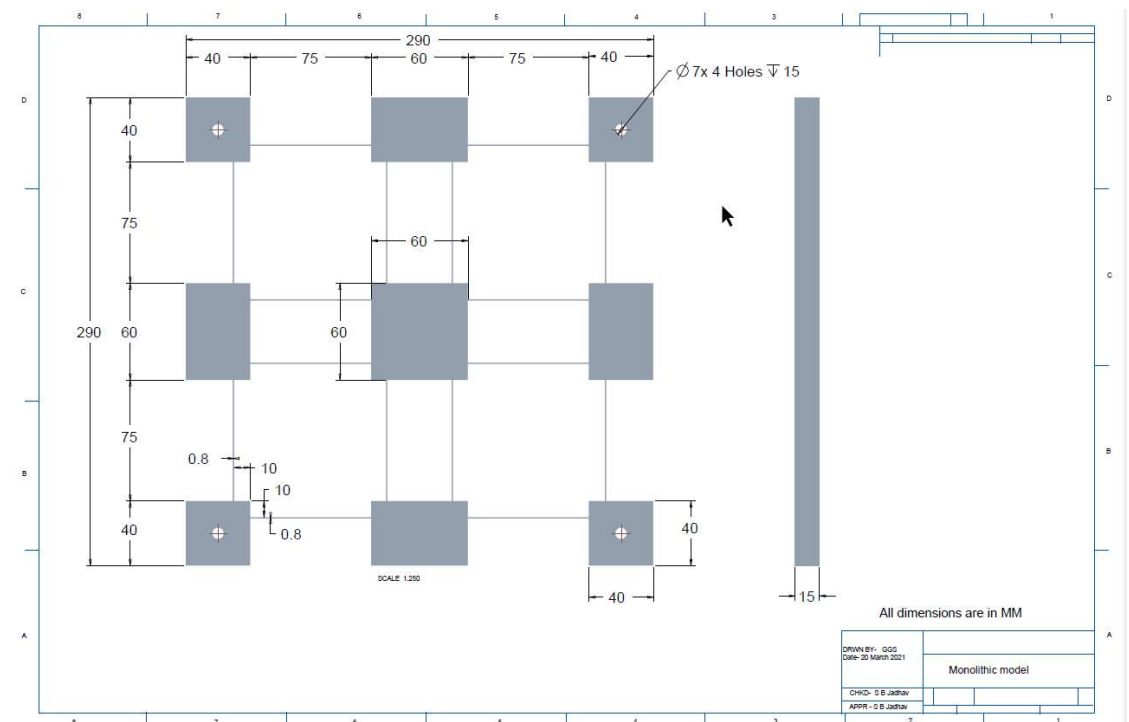

Fig3.1 monolithic model drawing

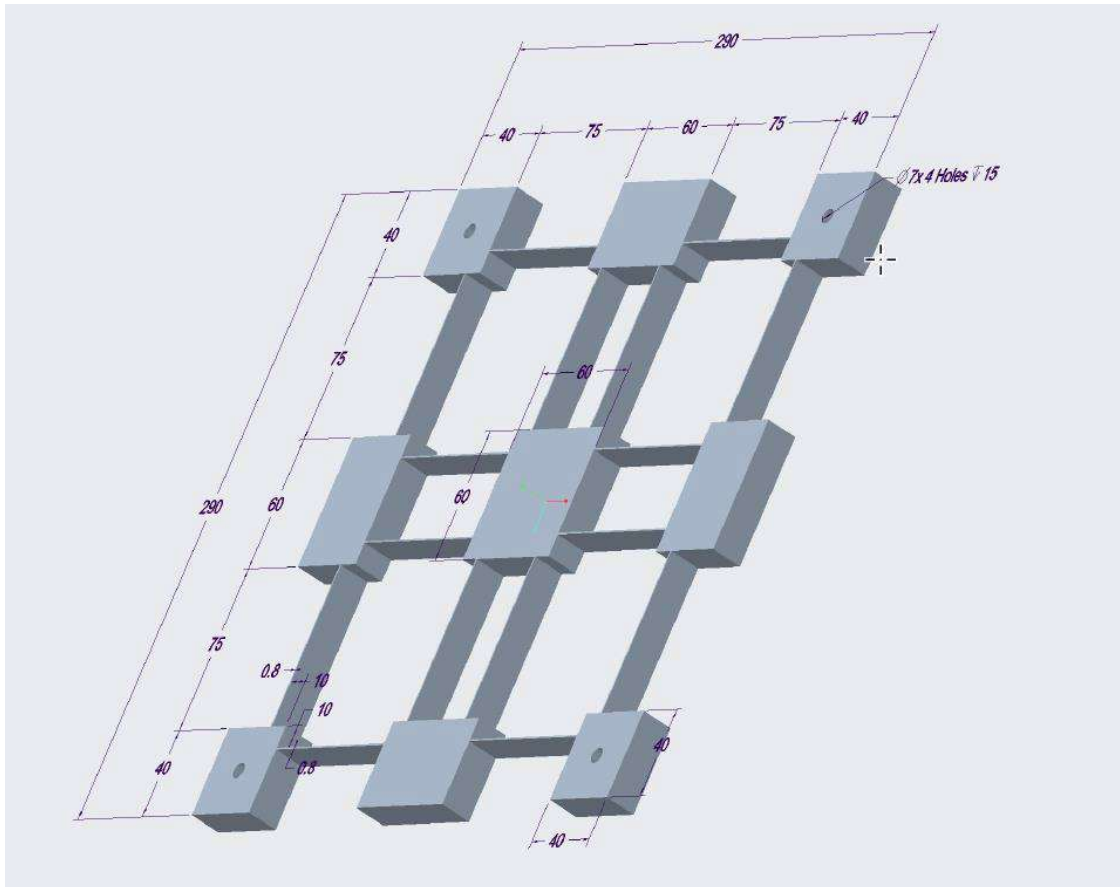

Fig3.2 Monolithic 3D model

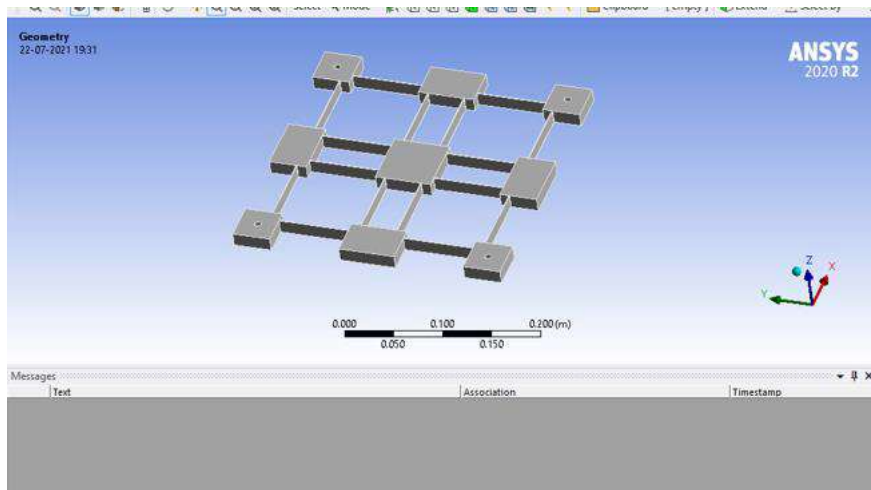

Fig 3.3 Monolithic model- pre-processing

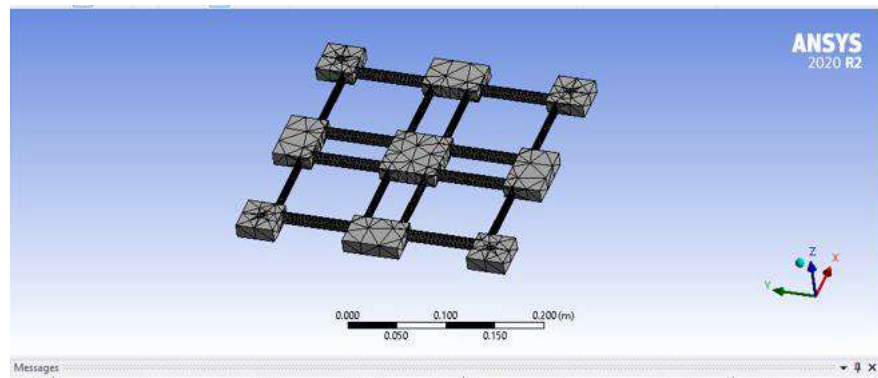
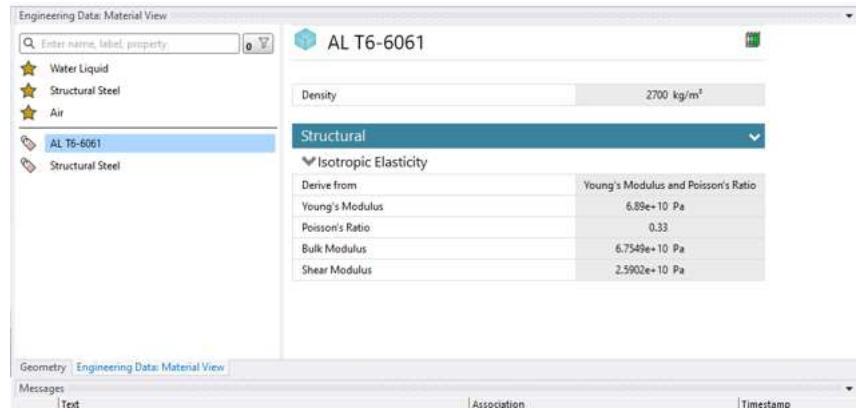

Fig 3.4 Monolithic model- meshing

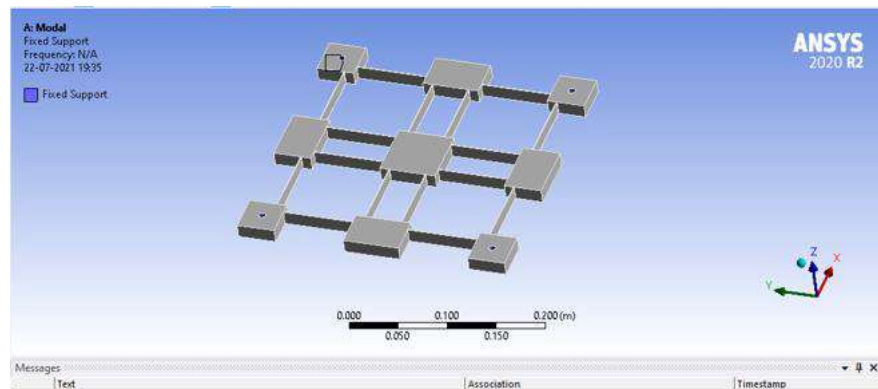

Fig 3.5 Modal Analysis

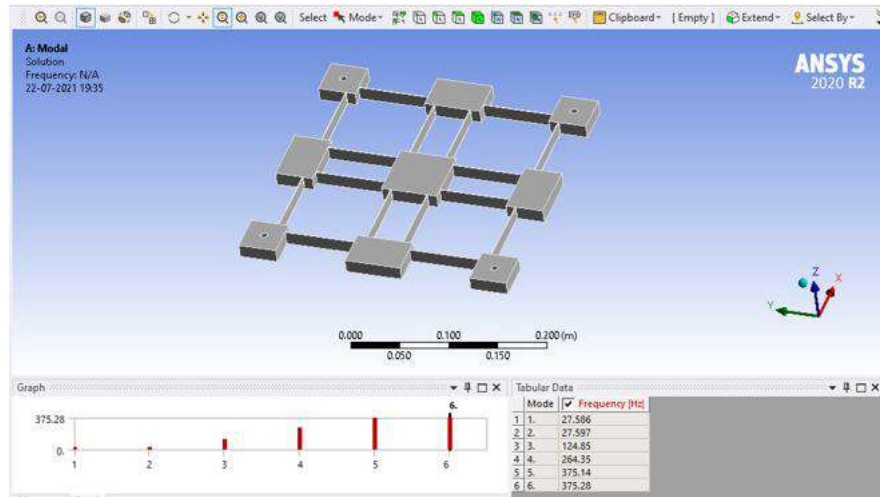

Fig 3.6 Modal Analysis stage 1

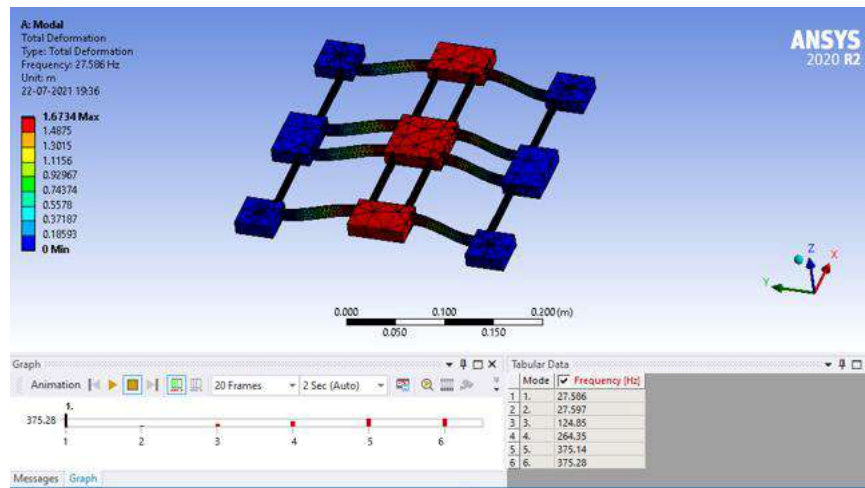

Fig 3.7 modal analysis -stage 2

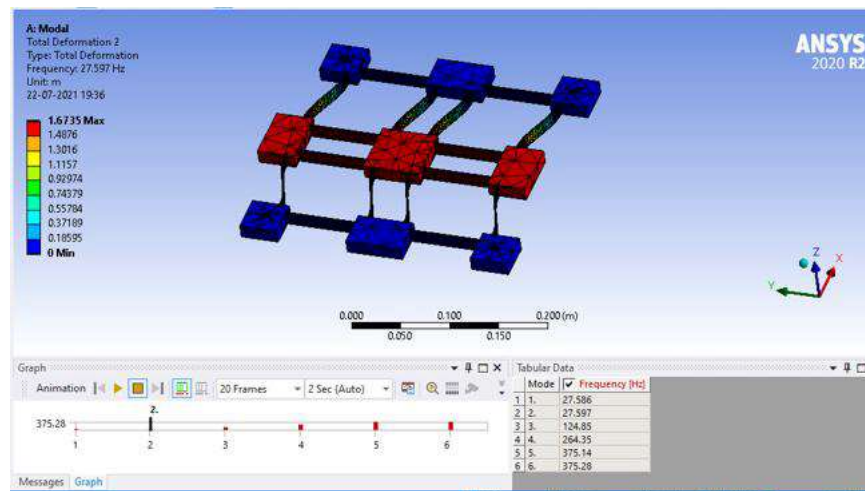

Fig 3.8 Modal analysis -stage 3

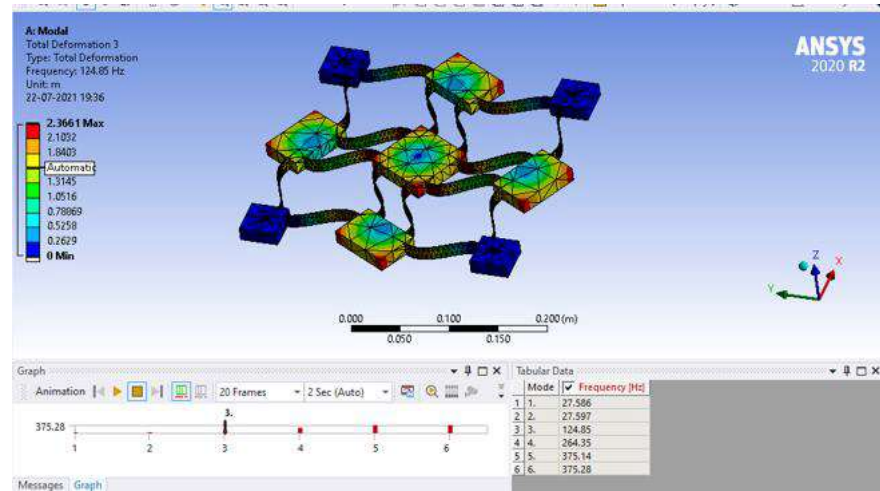

Fig 3.9 Model analysis -stage4

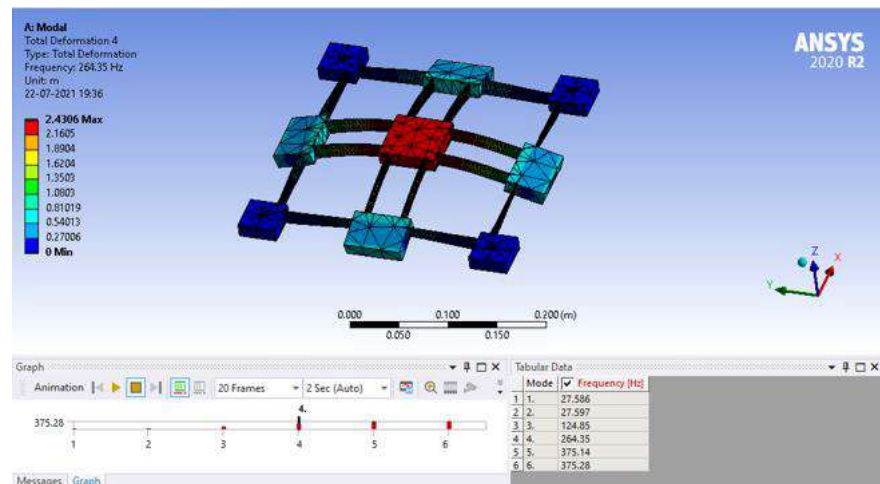

Fig 3.10 Random vibrations analysis

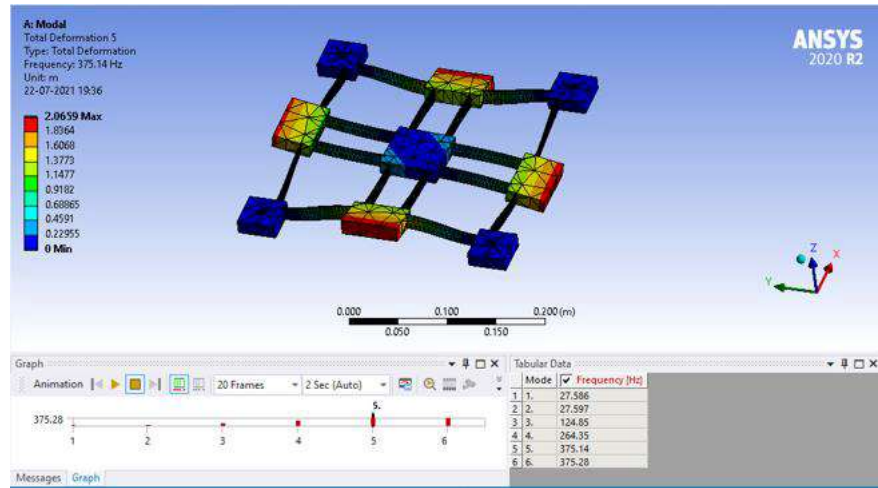

Fig 3.11 Random vibrations analysis-PSD

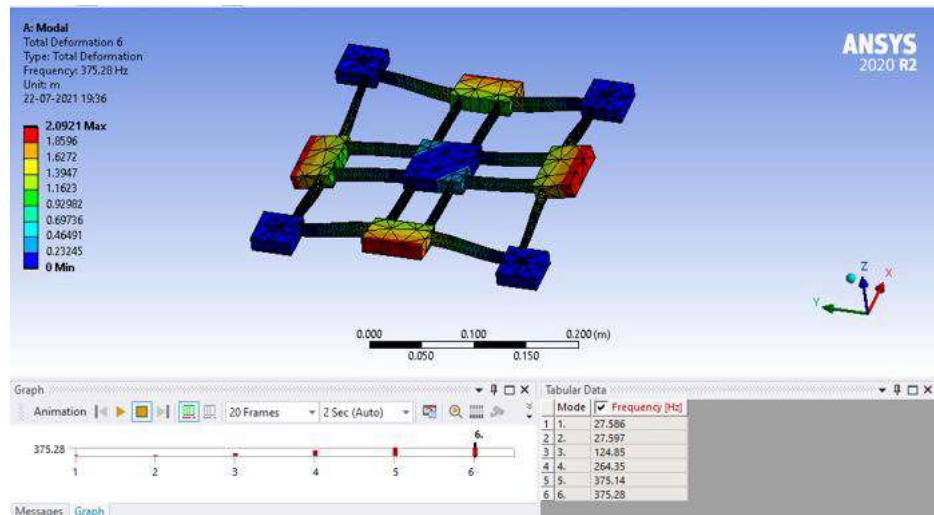

Fig 3.12 Random vibrations analysis-PSD

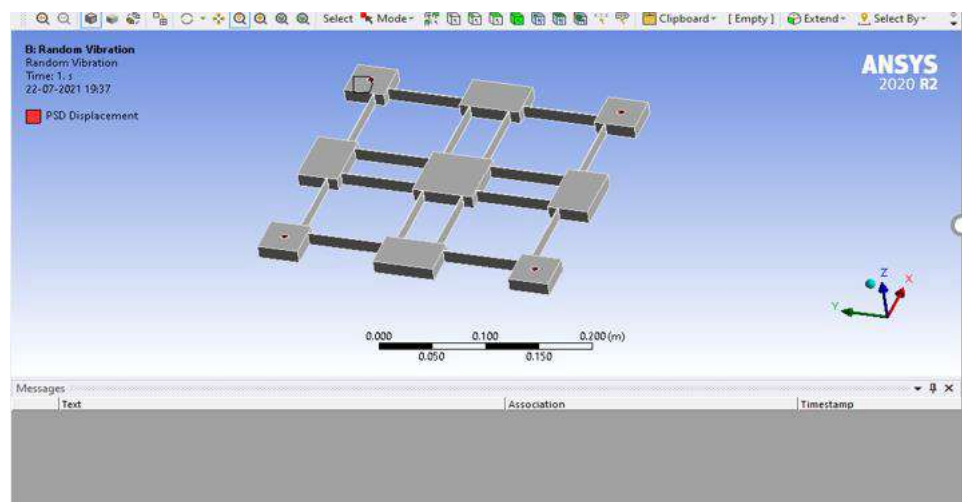

Fig 3.13 Random vibrations analysis

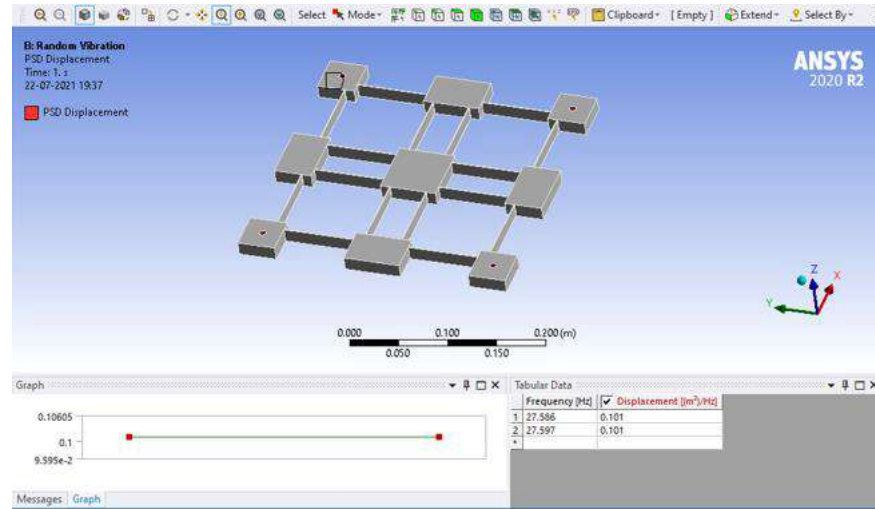

Fig 3.14 Random Vibration analysis

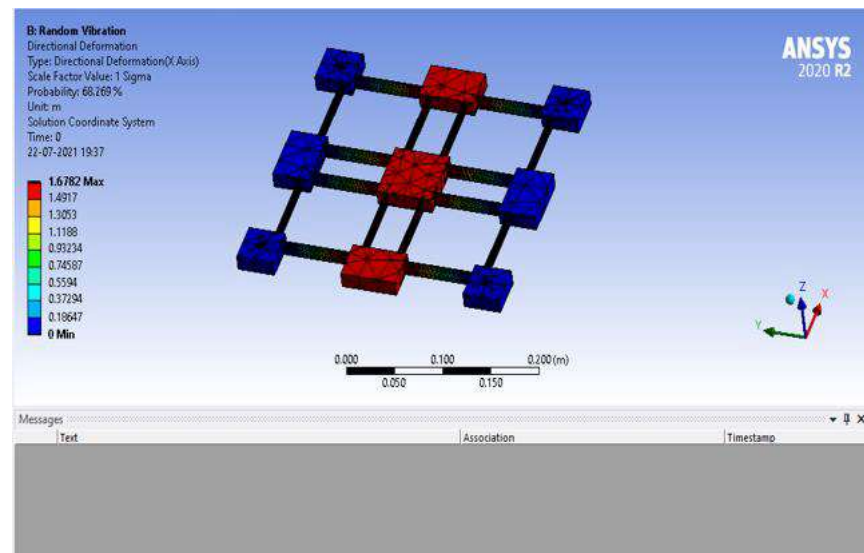

Fig 3.15 Random vibration Analysis

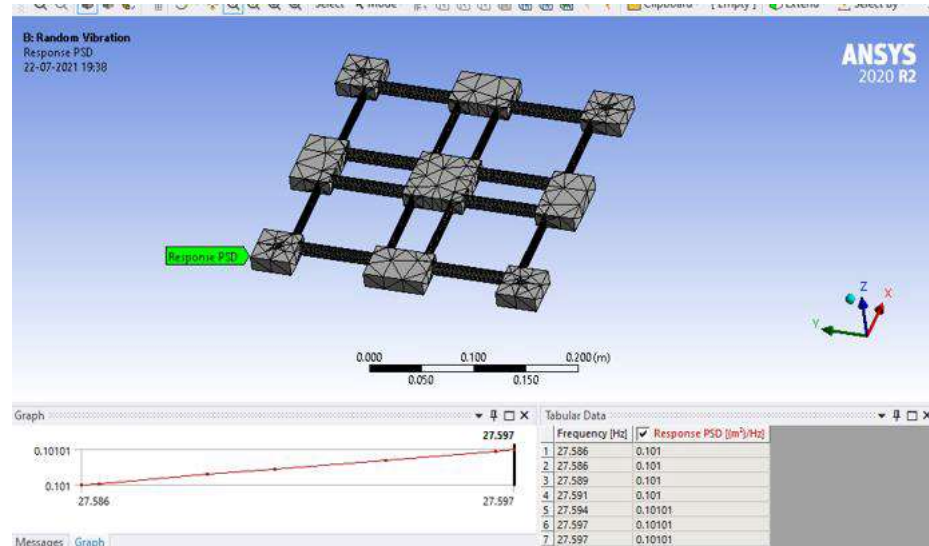

Fig 3.16 Random vibration Analysis- response PSD

Experiment:

For verification of theoretical characteristics of the compliant XY micro-motion stage, prototype is fabricated using Wire Electric Discharge Machining (WEDM). Voice coil actuator from BEI Kimco with a 30 mm stroke, 260 N peak force and force constant of 21.8 N/A. The output displacement is measured using high resolution linear optical encoder-Reni-shaw encoder (RELM scale Si-HN 4000 read head, SIGNUM interface) capable of 5 nm resolution, 80 mm measurement range. The optical encoder is mounted on carrier. System Integration is needed to connect the mechanism to the dSPACE and finally operate it with computer installed Graphical user interface software Control Desk. Actuating force is given to the mechanism after converting it into corresponding current-voltage. Since the current is of very value So it is amplified using linear current amplifier (LCAM). The force causes the motion stage move. The motion is detected by linear optical encoder installed in the system. The reading from encoder is further given to the dSPACE. A MATLAB Simulink model is prepared to compare this encoder signal with reference signal to calculate the error signal which acts as the actuating force. Finally all outputs from various devices are displayed using Control Desk which acts like the GUI between the user and the entire system. This way system integration is performed and set up is ready for experimentations.

IV. FUTURE SCOPE

- The study can be extended using different electromagnetic coupling architectures.
- Different coupling architectures are compared considering the energy harvesting capacity, weight and cost.
- One can change the geometry of the voice coil i.e. with or without back iron and explore their energy harvesting capacity using power spectral density.

REFERENCES

Papers from the Journal

[1a] A micro electromagnetic generator for vibration energy harvesting, January 2010

Dr. D. Y. Patil School of Engineering, Lohegaon, M.E. (Mechanical) (Design Engineering)

- [1] Jiqiang Wang, Simultaneous vibration suppression and energy harvesting Damping optimization for performance limit_2019.
- [2] Z.C. Ong a,ft, Y.X. Ooi a, S.Two-stage multi-modal system for low frequency and wide bandwidth vibration energy harvesting_2019.
- [3] Yi Li a, Shengxi, High performance low frequency bistable vibration energy harvesting plate with tip mass blocks_2019A. Praveen Kumar et al. “Crush performance analysis of combined geometry tubes under axial compressive loading” Procedia Engineering, Volume 173, Pages 1415-1422, May 2017.
- [4] Design and Evaluation of Compliant Modular XY Positioning Stage, sep2020
- [5] Review on Electrodynamical Energy Harvesters—A Classification, Apr2013
- [6] Design and experimental characterization of a tunable vibration-based electromagnetic micro-generator
- [7] An efficient low cost electromagnetic vibration harvester, December 2009
- [8] On energy harvesting from ambient vibration
- [9] Electric Power Acquisition from the Vibration of an Electric Vehicle using a Permanent Magnetic Linear Power Generator, December 2006
- [10] Vibration energy harvesting by magnetostrictive material, June2008
- [11] Dirk Spreemann , Yiannos Manoli, Electromagnetic Vibration Energy Harvesting Devices

Internet Sources

- [11] Available in the internet: <http://www.beikimco.com/>, state April 2018
- [12] <http://moticont.com/voice-coil-motor.htm>